

Wellisair is a patented device with an innovative technology to effectively eliminate viral risk, odours, VOC's and other hazards on a molecular level by the process of oxidation. Wellisair uses Hydroxyl radicals to disinfect, purify and clean air and surfaces with nature's own mechanisms removing 99.9% of all hazardous elements leaving an area protected by Wellisair biologically clean and safe to use

**Wellisair Technology**

Wellisair uses advanced technology that generates and expands hydroxyl radicals (OH) that by oxidation eliminates virus, bacteria, allergens, moulds, odours and volatile VOCs up to 99.9%.

Oxidisation and elimination of harmful particles occurs in a chain reaction starting at the Wellisair unit, the chain reaction will continue as long as there are particles in the vicinity to allow the process to continue. The OH radical particle will break down into individual harmless elements when there is no longer material to react with meaning no harmful residue is left unlike traditional cleaning methods.

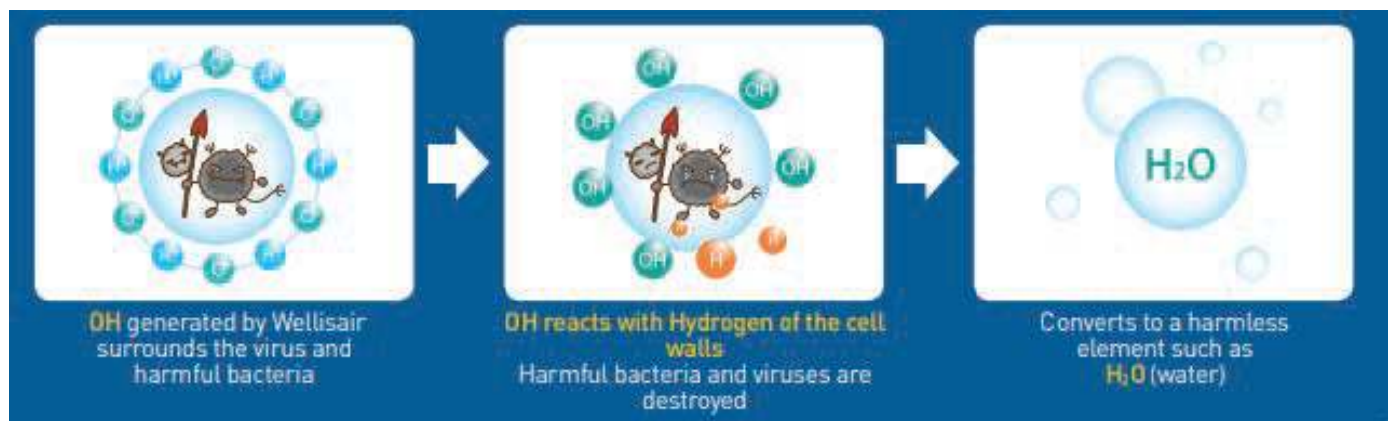

Hydroxyl radicals are naturally generated from sun light, ozone and moisture in the air. It is harmless, purifying substance generated naturally our process simply recreates this at a higher concentration allowing effective treatment of harmful pollutants.

**Applications**

**Ideal for any application**

The excellent decontamination capabilities of the Wellisair device make it the perfect solution for any indoor space. Typical applications include care homes, doctor waiting rooms, spa and beauty centres, cinemas supermarkets, warehouses, offices, gyms, shopping centres and educational centres.

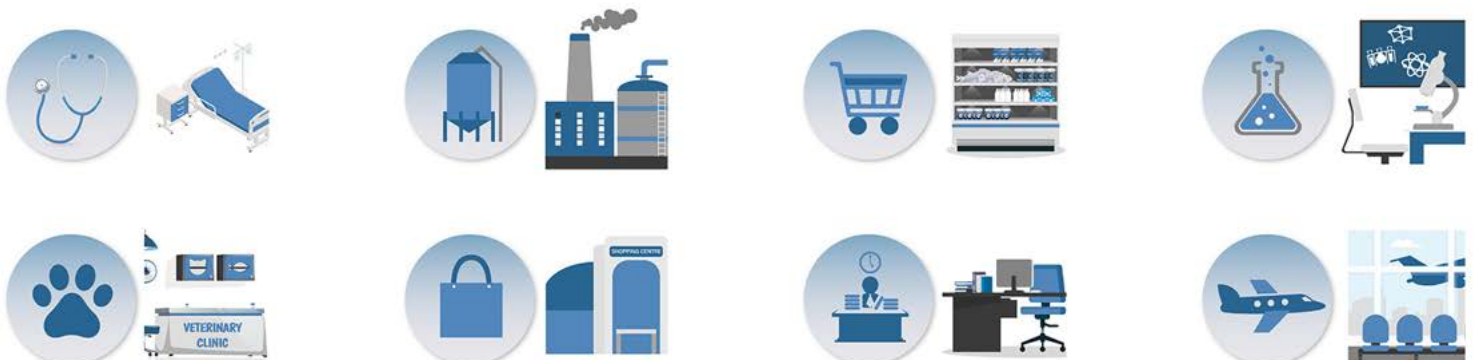

Features



- Purifier and disinfectant of air and surface device for enclosed spaces which produces and effectively spreads Hydroxyl radicals
- Removes 99.9% of existing viruses, bacteria, allergens, mould, odours and volatile organic compounds (VOCs).
- Compact and smart design with rounded shapes and radius.
- Very low electric consumption: 3.6 watts per hour.
- Works with cartridges charged with Limonene solution. Each cartridge has a 3 month lifetime.
- Tactile keypad with buttons: ON/OFF, night mode and alarm indicators.
- Low sound level.
- The night mode turns OFF the led and reduces the device noise.

**Easy control and compact design**



**Automatic Operation**  
Automatically purifies airborne and surface contaminants



**Night Mode**  
Minimal noise, Quiet functioning, Low brightness for comfortable sleep



**Cartridge Alarm**  
Lets you know in advance when you need replace cartridge



**Alert**  
Notifies in case of empty cartridge or when improper inserting causes a stop in function

# WELLISAIR | Air and Surfaces Purifier and Disinfection Unit

## Dimensions

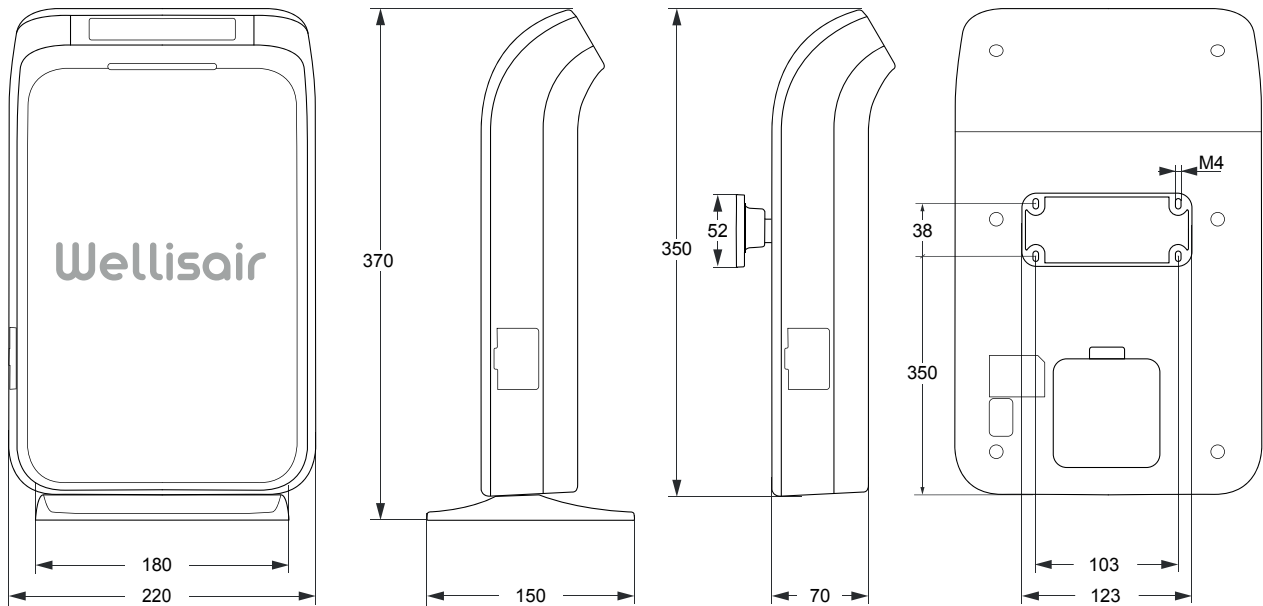

## Supplies

### Easily Replaceable



Replace the cartridge every 3 months

(The operating life of consumable fluid cartridge varies depending on environment, including indoor temperature, humidity, etc.)